

VANITIES  
BY ELECTRIC MIRROR®



EM

GOLDDILOCKS™

# GOLDDILOCKS™

VANITIES  
BY ELECTRIC MIRROR®

Dimensions: 36"W x 21"D x 32 1/2"H

## Materials:

- Countertop: Golden Silk Carrara (QT-1003, Polished)
- Wood Finish: Blonde Blush (WD-1010), 20% sheen

Countertop

Wood Finish



Golden Silk Carrara



Blonde Blush

EM Mirror: [Eminence™ Lighted Mirror](#)



## Features & Benefits

- 2 cm polished quartz countertop in Golden Silk Carrara (QT-1003).
- Quartz surfaces are highly resilient, nonporous, and scratch-and stain-resistant.
- Crafted with 3/4" plywood substrate with mindy veneer.
- Stained wood finish in Blonde Blush (WD-1010) on mindy veneer, with a 20% sheen achieved through a multistep finishing process.
- Vessel-style solid surface sink featuring a soft, organic curve, offering a smooth, natural aesthetic that feels modern yet understated.
- Includes an upper and lower shelf crafted in the same Mindy Veneer, finished in Blonde Blush.
- Features one (1) 5-sided dovetail drawer boxes for additional storage.
- Equipped with premium undermount soft-close drawer slides for smooth, quiet operation.
- Freestanding design with cleat attachment for added security and stability.

## Manufacturing & Quality Requirements

- All items must be of contract-grade quality, suitable for high-end hospitality use.
- Products must comply with local, state, national, and international codes, including ADA guidelines and fire/life safety regulations.
- Manufacturer must submit certificates of compliance, installation guidelines, maintenance instructions, and warranty documentation.
- All wood must be kiln-dried hardwood, marine-grade plywood, or waterproof MDF.
- Veneers must be A/B grade, with consistent grain and finish.
- All exposed edges must be sealed for moisture resistance.
- Finishes must be commercial-grade catalyzed lacquer, resistant to water, alcohol, and chemical stains.
- Vanities must be impact- and scratch-resistant, with matching finish on all sides and interiors.
- Drawer boxes must feature five-sided dovetail construction. Where plumbing interference exists, a U-shaped configuration should be used to maintain functionality without compromising structural integrity.
- All work must be corner blocked, glued, and reinforced with screws or appropriate mechanical fasteners.
- Use premium undermount soft-close slides and concealed soft-close hinges.
- All metal components and hardware must be made from 304 stainless steel, offering rust and corrosion resistance suitable for most environments. For coastal or high-humidity locations, 316 stainless steel must be used to ensure enhanced durability and protection against salt exposure.
- All exposed hardware finishes must be approved prior to production.
- Leveling glides must be heavy-duty, non-rust nylon, sized and colored to match the base or leg finish.
- Units must be properly packaged to prevent damage or soiling during transit.
- Shipping boxes must be labeled with property name, item number, PO number, and spec number.
- All products must be designed to fit within service elevators, corridors, and doorways. If not, items must be shipped in knock-down state for on-site assembly.
- Manufacturers must submit scaled shop drawings with full details (plans, elevations, sections, materials, finishes, hardware, dimensions).
- Finish samples must be submitted on appropriate substrates for approval prior to production.
- Review time for submittals is 5 business days.
- All substitutions or changes must be approved in writing by the designer.
- Coordinate with general contractor to confirm elevator cab sizes, corridor widths, and mounting heights.
- Manufacturers must ensure products are structurally sound, properly weighted to prevent tipping, and bolted where required (e.g., earthquake zones).

# TECHNICAL DRAWINGS

**VANITIES**  
BY ELECTRIC MIRROR®

**Faucet**

**Finish:** Antique Brass

(The 3D model is for reference only)

**Sink: XA-A79**

**Finish:** Designer White

**Size:** 420 x 340 x 150 mm

(The 3D model is for reference only)

VINA Quartz TOP

Calcutta Rainbow [VQ8098W-Q]

EXPLODED VIEW

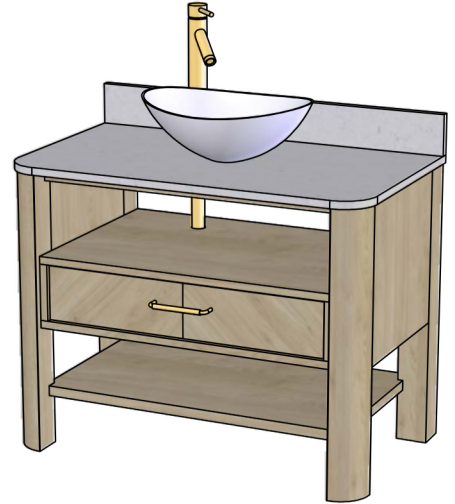
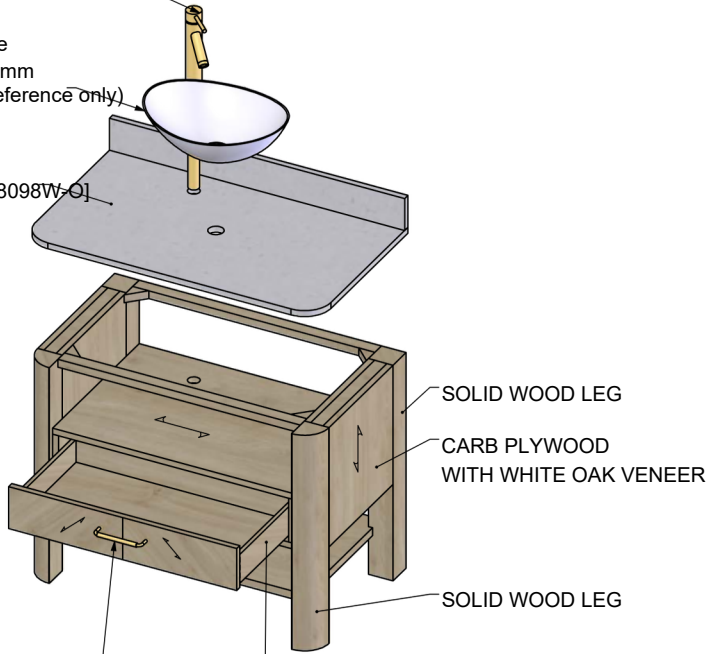

6" Hardware

**Model #:** West Elm

Knurled Drawer Hardware - Antique Brass

14" FULL EXTENSION SOFT CLOSING UNDER-MOUNT DRAWER SLIDES.LOAD CAPACITY 35KG

