

VANITIES
BY ELECTRIC MIRROR®



EM

STELLA™

Dimensions: 60"W x 24"D x 34"H

Materials:

- Countertop: Calcatta White (QT-1005), Polished
- Metal Finish: Brushed Brass (BR-02)

Metal Finish



Brushed Brass

Countertop



Frosty Chateau
Solid Surface

[EM Mirror: Radiance™ Lighted Mirror](#)



Features & Benefits

- 5.08 cm (2") polished Calcatta White (QT-1005) Quartz countertop.
- Features a quartz apron, creating the appearance of a waterfall countertop.
- Quartz surfaces are highly resilient, nonporous, and scratch-and stain-resistant.
- Includes a rectangular undermount vitreous China sink.
- Stainless steel base finished in Brushed Brass (BR-02).
- Includes a tempered smoked glass shelf, offering stylish and functional storage.
- Freestanding design with cleat attachment for added security and stability.

Manufacturing & Quality Requirements

- All items must be of contract-grade quality, suitable for high-end hospitality use.
- Products must comply with local, state, national, and international codes, including ADA guidelines and fire/life safety regulations.
- Manufacturer must submit certificates of compliance, installation guidelines, maintenance instructions, and warranty documentation.
- All wood must be kiln-dried hardwood, marine-grade plywood, or waterproof MDF.
- Veneers must be A/B grade, with consistent grain and finish.
- All exposed edges must be sealed for moisture resistance.
- Finishes must be commercial-grade catalyzed lacquer, resistant to water, alcohol, and chemical stains.
- Vanities must be impact- and scratch-resistant, with matching finish on all sides and interiors.
- Drawer boxes must feature five-sided dovetail construction. Where plumbing interference exists, a U-shaped configuration should be used to maintain functionality without compromising structural integrity.
- All work must be corner blocked, glued, and reinforced with screws or appropriate mechanical fasteners.
- Use premium undermount soft-close slides and concealed soft-close hinges.
- All metal components and hardware must be made from 304 stainless steel, offering rust and corrosion resistance suitable for most environments. For coastal or high-humidity locations, 316 stainless steel must be used to ensure enhanced durability and protection against salt exposure.
- All exposed hardware finishes must be approved prior to production.
- Leveling glides must be heavy-duty, non-rust nylon, sized and colored to match the base or leg finish.
- Units must be properly packaged to prevent damage or soiling during transit.
- Shipping boxes must be labeled with property name, item number, PO number, and spec number.
- All products must be designed to fit within service elevators, corridors, and doorways. If not, items must be shipped in knock-down state for on-site assembly.
- Manufacturers must submit scaled shop drawings with full details (plans, elevations, sections, materials, finishes, hardware, dimensions).
- Finish samples must be submitted on appropriate substrates for approval prior to production.
- Review time for submittals is 5 business days.
- All substitutions or changes must be approved in writing by the designer.
- Coordinate with general contractor to confirm elevator cab sizes, corridor widths, and mounting heights.
- Manufacturers must ensure products are structurally sound, properly weighted to prevent tipping, and bolted where required (e.g., earthquake zones).

TECHNICAL DRAWINGS

VANITIES

BY ELECTRIC MIRROR®

BR-02: BRUSHED BRASS
 QT-1005: CALCUTTA WHITE QUARTZ, POLISHED
 SINK: SERANO, UNDERMOUNT VITREOUS CHINA WHITE
 FAUCET: 3-PIECE FAUCET

EXPLODED VIEW

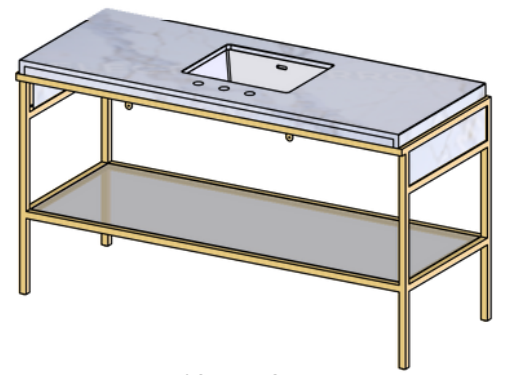
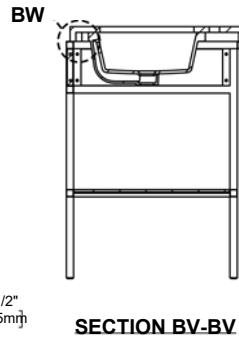
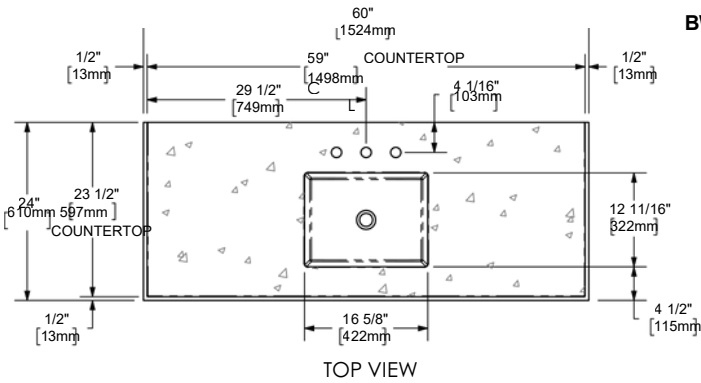
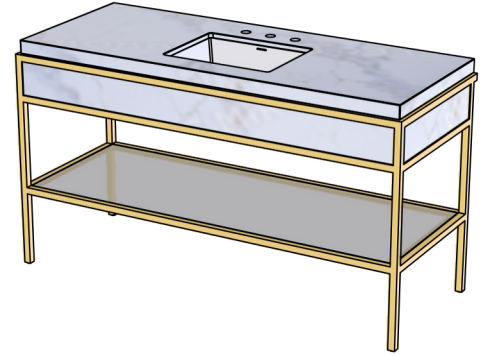
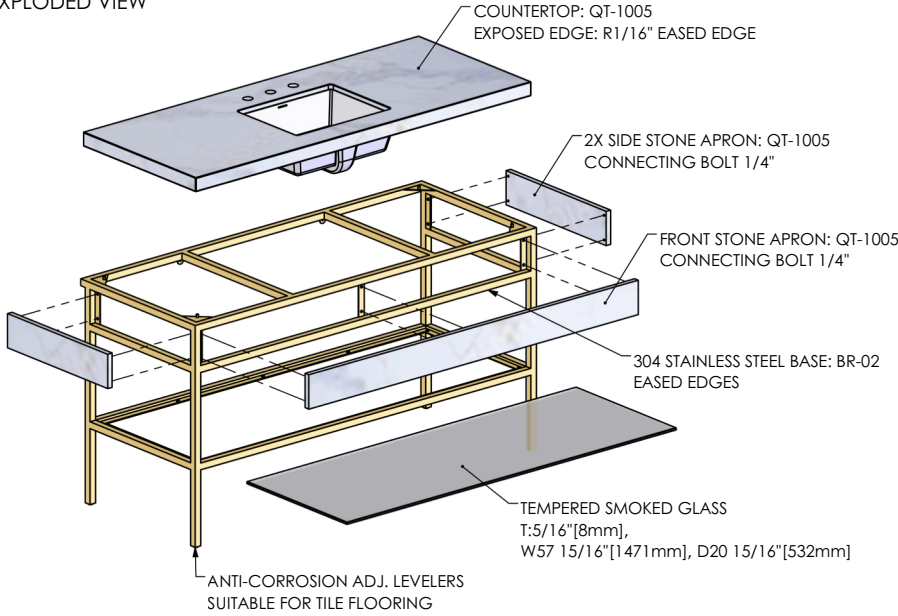

ISOMETRIC VIEW

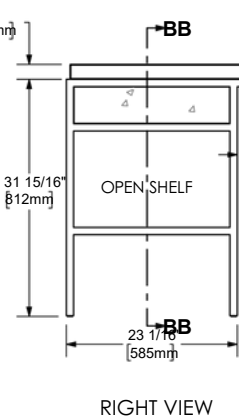
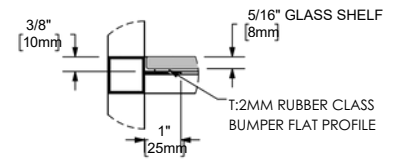
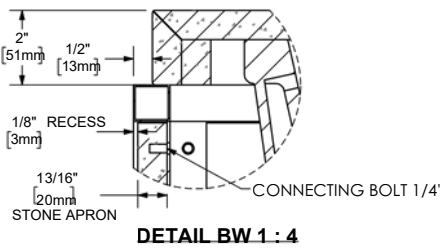
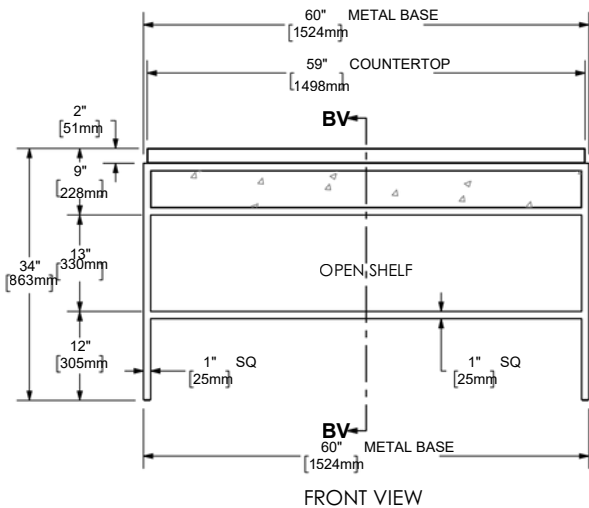

2X Ø5MM MOUNTING HOLES TO ATTACH TO FINISHED WALL

